

# Amphenol

## HMA*two*

### Legacy Fibre Optic Connectors



Amphenol introduces the HMAtwo Series into the Harsh Environment product portfolio. This legacy hermaphroditic fibre optic lens connector facilitates the inter-connection of multiple identical fibre optic cable assemblies known as daisy chaining, thus eliminating the need for polarising the assemblies and the use of in-line adapters. Lens technology is less vulnerable to mud, dirt and other contaminants than the traditional physical contact technology. This allows rapid and reliable deployment of assemblies in extreme environments. The Connector is available in 1 to 4 way configurations for multi-mode fibres at both 850 and 1300nm applications and is inter-mateable/interchangeable with other manufacturers equivalent products.

The standard connector components are aluminium with a long life Hard Black anodise finish with the coupling ring featuring a protective "rubber" overmould. The connector has been designed for both factory and field termination directly onto standard tactical fibre optic cable without specialist lens termination tooling. The connector construction allows for both first line field repairs and return to base overhauls of both the connector and the Lens assembly.

#### Features

- Proven Expanded Beam technology
- Interchangeable and intermateable with alternative manufacturers products
- Maximum 1.5dB optical performance – Multimode / Singlemode
- Field cleanable and repairable
- Waterproof
- Singlemode available upon request

#### Applications

- Military
- Outside broadcast
- Industrial/Geophysical

#### Materials

- Hard Anodised Aluminium
- Aluminium Nickel Bronze
- Brass
- Stainless Steel

## Technical Specifications

Environmental Performance	
Storage Temperature	-55 to +85°C
Operating Temperature	-40 to +70°C
Humidity	+65°C, 90% RH
Mechanical shock	100g, 6ms
Tensile strength	1750N (cable dependent)
Vibration	10-500hz, 0.75 amplitude @ 10g acceleration
Mating cycles	1000 cycles
Water Immersion	Up to 5M depth

Optical Performance	
Insertion Loss	62.5/125 @ 1300nm 1.0dB Typical
Fibre Types	50/125, 62.5/125µm
Cable Types / Variants	5.5mm OD Tactical 4 Core – 014 3mm OD Ruggedised Simplex -011 (Receptacle only) 900µm Buffered fibre – 040 (Receptacle only)

## Connector Part Number Configuration

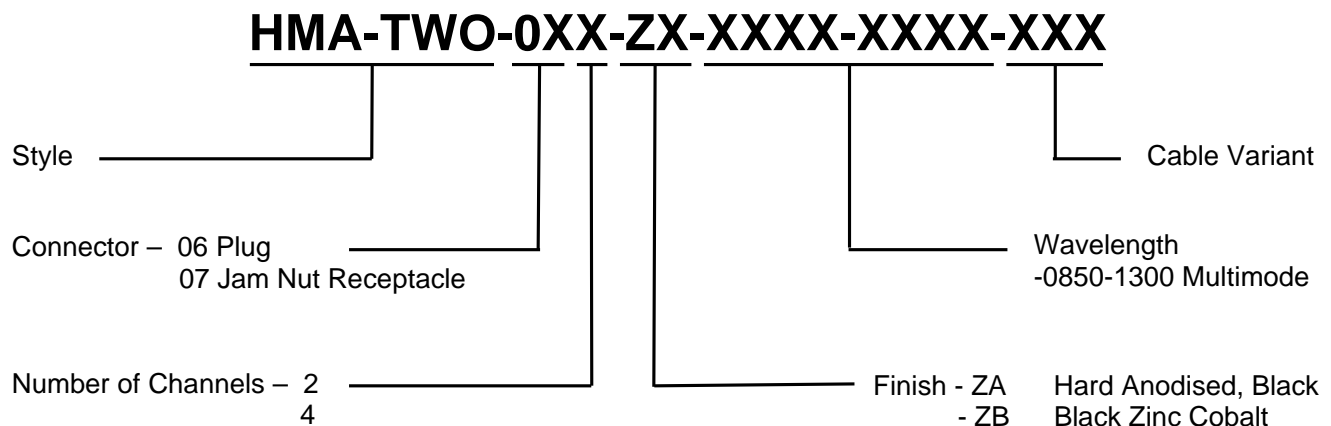

## Connector Part Number Example:

HMAtwo 2ch Plug, Multimode to suit 5.5mm tactical cable :-

**HMA-TWO-062-ZA-0850-1300-014**

-014 Suitable with 5.5mm diameter  
Military Tactical Fibre cable

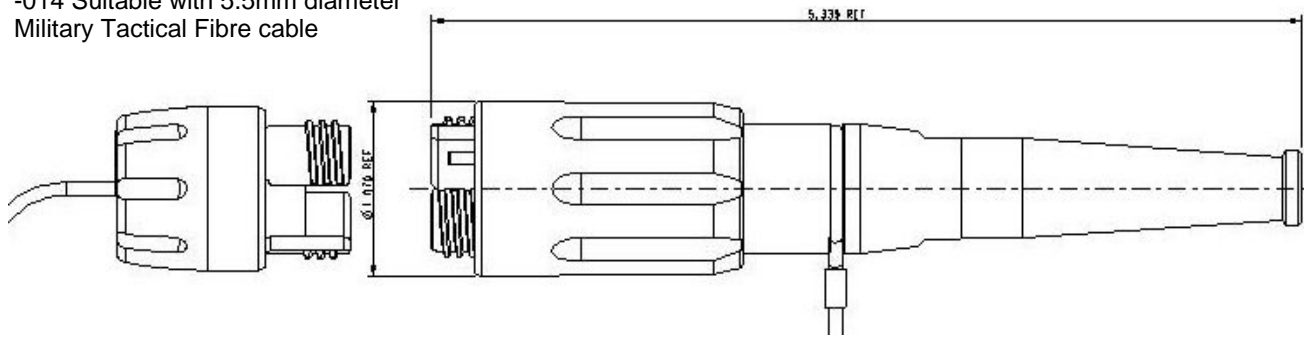

### HMAtwo Jam Nut Receptacle

-040 Suitable with 900µm  
Buffered fibre

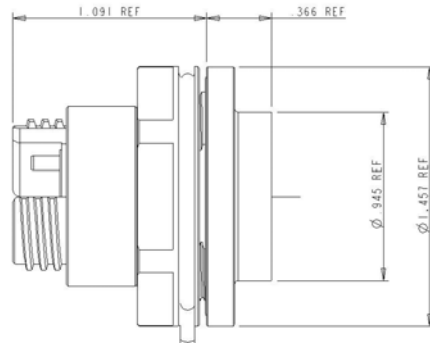

-011 Suitable with 2-3mm  
Simplex Ruggedised cable

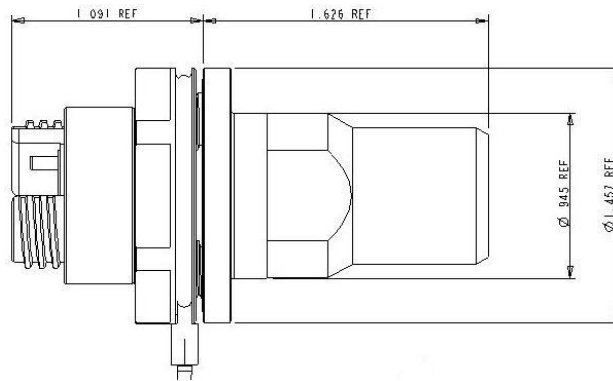

-014 Suitable with 5.5mm diameter  
Military Tactical Fibre cable

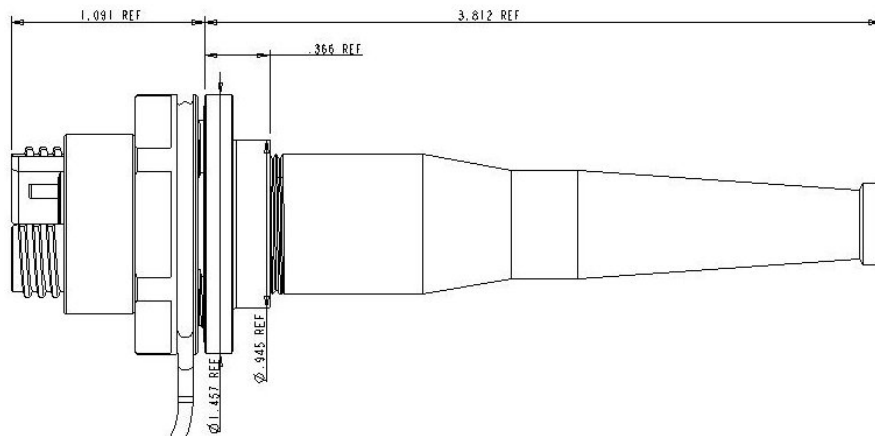

## Panel Cut-Out details - Jam Nut Receptacle

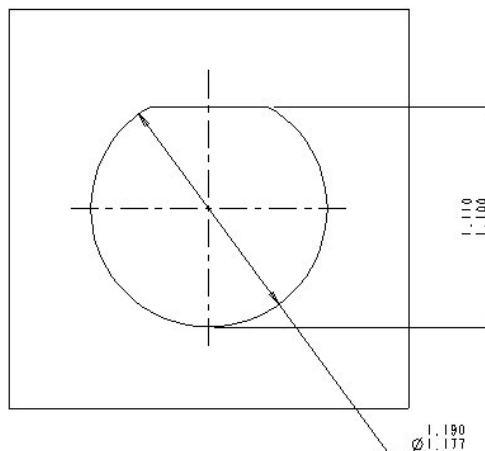

## Accessories - Hermaphroditic Protective Cap

Part Number: 960-994-100

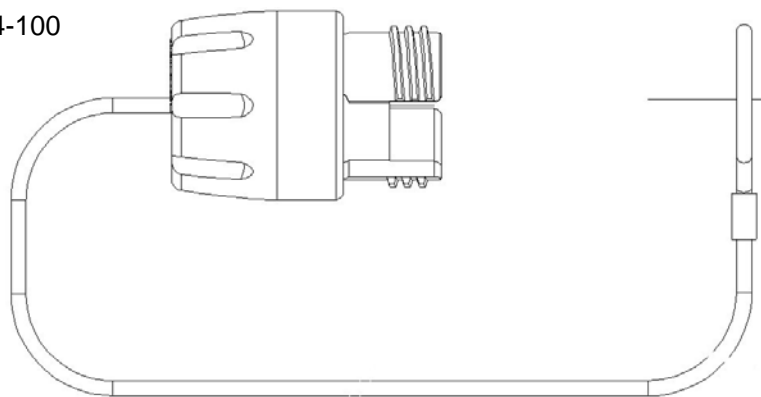

1.5mm Dia Cord  
150mm Long

## Termination 'Add-on' Tool Kit - Part Number: 927-100-5311

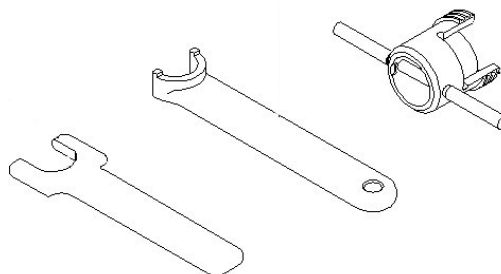

Amphenol Limited manufacture cable assemblies for all applications which can be supplied on field deployable drums. Please contact the Amphenol factory for part numbers and quotations

**Notice:** Products are sold subject to Amphenol's conditions of sale ("the standard conditions"). All specifications and statements contained herein are believed to be correct at the time of printing but no representation or warranty, express or implied, is given as to any specification or statement contained herein. Product specifications including performance characteristics are typical only and subject to deviation. Specifications are also subject to change without notice. Users should not assume that all safety measures are indicated or that other measures may not be required. No representation or warranty, express or implied, is given that any use of products (including any stated or suggested use) does not infringe any patent, registered design or other third party rights and no stated or suggested use of products can be taken to recommend any such infringement.

**Amphenol**

Thanet Way, Whitstable, Kent. CT5 3JF Tel: 01227 773200 Fax: 01227 276571